

# Captive Screw Type 5 10-32 Thread

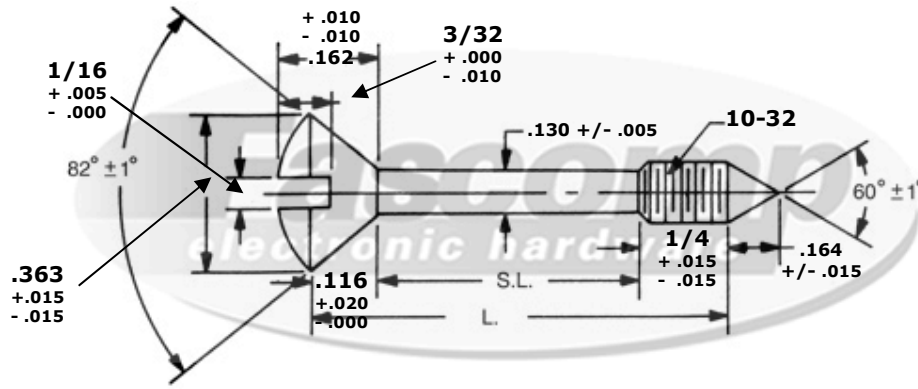

Create a part number:

Length	Material	Finish
FCXXXX	XX	XX
_____ - _____ - _____		

## Captive Screws - 10-32 Thread

FCXXXX	Length (L)	S.L. REF
FC0968	1/2	1/8
FC0969	9/16	3/16
FC0970	5/8	1/4
FC0971	11/16	5/16
FC0972	3/4	3/8
FC0973	13/16	7/16
FC0974	7/8	1/2
FC0975	15/16	9/16
FC0976	1	5/8
FC0977	1-1/16	11/16
FC0978	1-1/8	3/4
FC0979	1-3/16	13/16
FC0980	1-1/4	7/8
FC0981	1-5/16	15/16
FC0982	1-3/8	1
FC0983	1-7/16	1-1/16
FC0984	1-1/2	1-1/8
FC0985	1-9/16	1-3/16
FC0986	1-5/8	1-1/4
FC0987	1-11/16	1-5/16
FC0988	1-3/4	1-3/8
FC0989	1-13/16	1-7/16
FC0990	1-7/8	1-1/2
FC0991	1-15/16	1-9/16
FC0992	2	1-5/8

## Material

Material Code (XX)	
B	Brass
S	Steel
SS	Stainless Steel

## Compatible Finish (XX)

B, S, SS	0 - Plain
B, S	5 - Nickel Plate (QQ-N-290)
B, S	12 - Zinc Clear (ASTM-B-633)
B, S	16 - Electro Tin (MIL-T-10727 TYPE 1)
SS	20 - Passivation (MIL-F-14072D)
B, S, SS	26 - Black Oxide
B, S	28 - Zinc Yellow (ASTM-B-633)

Source Control Drawing:  
To be produced by  
Fascomp Electronic Hardware

**Tolerances**  
**Unless otherwise Specified**  
.xxx +/- .005  
.xx +/- .010  
Angular +/- 1 Degree  
Linear +/- .005  
**Break all sharp edges**



This document is the property of Fascomp Inc. and shall not be reproduced, distributed, or used as a basis for manufacturing without written permission from Fascomp Inc.